



TEST REPORT Nr. 095 SŠF/13 VOA en

Page (pages)

05 of August 2013

**Window air permeability measurement,
watertightness and resistance to wind load**

(designation of the test)

Test performed: In accordance to watertightness LST EN 1027:2004, air permeability measurement LST EN 1026:2004, resistance to wind load LST EN 12211:2002
(number of normative document)

Product: Wooden (glued pine) window. Measurements: width 1230 mm, height 1480 mm, frame thickness 155 mm. Opening: with a vertically sliding frame. Hardware: sash pulleys SBBCHR, fasteners HERITLOCKCH, sash lifts SLCHZ. Gaskets: SHLEGEL QL-3078-1-500 (4 units) and brushes (Weatherpile in Self-Adhesive Carrier) code cw511 (2 units). Glazing: 4-16Arg-4GNP (two glasses, one glass with low emission cover, spacer bars – Thermix, space between the glasses filled with argon).
(name, description and identification details of a specimen)

Results of test:

Name of the indicator and unit	Test method reference no.	Test result
Watertightness, class	LST EN 1027:2004	7A
Air permeability, class	LST EN 1026:2004	3
Resistance to wind load, test pressure, class	LST EN 12211:2002	3
Resistance to wind load, frame deflection, class	LST EN 12211:2002	C

Note. The testing are carried out in purpose for conformity assessment of the product according to LST EN 14351-1:2006+A1:2010

Place of test: Science Laboratory of Building Thermal Physics, Institute of Architecture and Construction of Kaunas University of Technology
(name of the test laboratory)

Product delivered: 2013-08-01 Date of test: 2013-08-02

Sample selected: by customer. Sampling Report N₀. 095/13, 2013-08-01

Other information: Application 2013-08-01 drawing

(other deviations, other tests and any information related to the test)

Annex: 1 – measurement results, 2 – schematical view of the test rig

(the numbers of the annexes should be pointed out)

Technical manager:

(approving test results)

(signature)

J. Ramanauskas

(n., surname)

Test performed by:

(person responsible for a test)

(signature)

R. Rauckis

(n., surname)

S.P.

Validity – the named data and results refer exclusively to the tested and described specimens.
Notes on publication – no part of this document may be photocopied, reproduced or translated to another language without the prior written consent of the Science Laboratory of Building Thermal Physics

Installation of the sample

Sample has been installed into test rig „KS 3025/45 ASD SPS Touch“ opening by workers of the laboratory. An opening of the test rig was adjusted that it size would meet the dimensions of the sample.

The ambient temperature and humidity close to the specimen shall be within the range 10 °C to 30 °C and 25 % to 75 % RH and the specimen shall be conditioned thus for at least 4 h immediately before test.

Methods and equipment

Air permeability has been tested in accordance with requirements of [2], [4].

Test rig „KS 3025/45 ASD SPS Touch“ includes:

1. Test wall,
2. Air flow control block,
3. Water sprinkling system,
4. Indication and control equipment,
5. Deflection sensors.

Technical data of test rig:

1. Max size of the sample should be tested: width – 3000 mm, height – 2500 mm,
2. Max developed test pressure: ± 3000 Pa,
3. Ranges of measurement: I – (0,5...50) m³/h II – (0,5...300) m³/h,
4. Range of displacement sensors ± 25 mm.
5. Electronic anemometer for air flow measurement VTS Nr. 00100173, Calibration certificate No EMA04271024139 (date of calibration: 27-10-2004)

Test rig „KS 3025/45 ASD SPS Touch“ tried LEI Nr. 43/09-D, 2009-03-06

- Sources**
- [1] *LST EN 1027:2004 Windows and doors - Watertightness – Test method.*
 - [2] *LST EN 12208:2002 Windows and doors - Watertightness - Classification.*
 - [3] *LST EN 12207:2002 Windows and doors- Air permeability – Classification.*
 - [4] *LST EN 1026:2004 Windows and doors- Air permeability – Test method.*
 - [5] *LST EN 12211:2002 Windows and doors – Resistance to wind load – Test method.*
 - [6] *LST EN 12210:2002 Windows and doors – Resistance to wind load – Classification.*
 - [7] *LST EN 12210+AC:2004 Windows and doors – Resistance to wind load – Classification.*
 - [8] *LST EN 14351-1:2006+A1:2010 Windows and doors - Product standard, performance characteristics - Part 1: Windows and external pedestrian doorsets without resistance to fire and/or smoke leakage characteristics*

Distribution: Client Original
Science Laboratory of Building Thermal Physics,
Institute of Architecture and Construction of Kaunas
University of Technology Original

Contact person: Romas Rauckis, tel. +370 37 350779

Validity – the named data and results refer exclusively to the tested and described specimens. Notes on publication – no part of this document may be photocopied, reproduced or translated to another language without the prior written consent of the Science Laboratory of Building Thermal Physics.

1 Annex. Measurement results

Designation of the product tested: Wooden (glued pine) window. Measurements: width 1230 mm, height 1480 mm, frame thickness 155 mm. Opening: with a vertically sliding frame. Hardware: sash pulleys SBBCHR, fasteners HERITLOCKCH, sash lifts SLCHZ. Gaskets: SHLEGEL QL-3078-1-500 (4 units) and brushes (Weatherpile in Self-Adhesive Carrier) code cw511 (2 units). Glazing: 4-16Arg-4GNP (two glasses, one glass with low emission cover, spacer bars – Thermix, space between the glasses filled with argon).

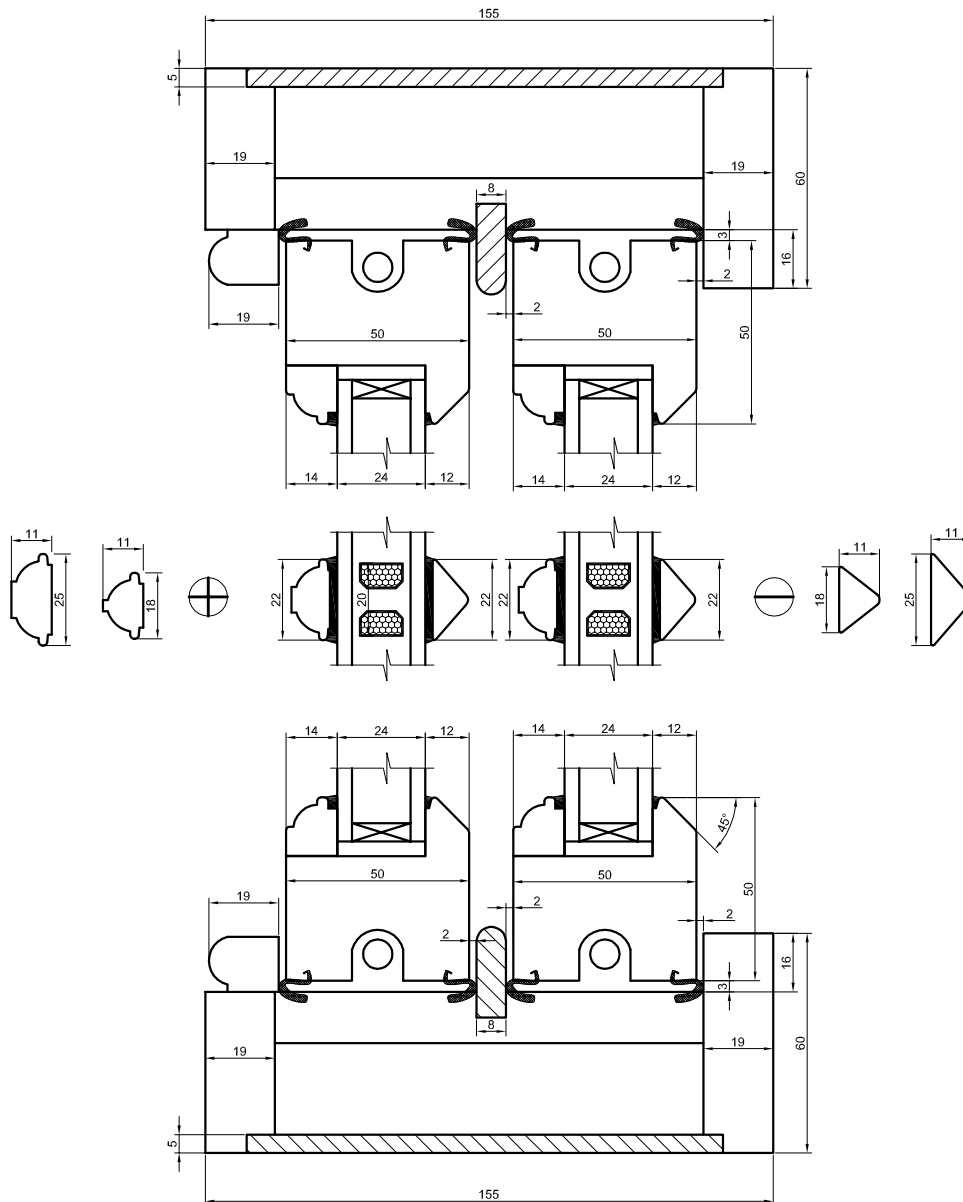

		Horizontal section		
-		Sash Window		
				0
		Spiral balance		
			1	2

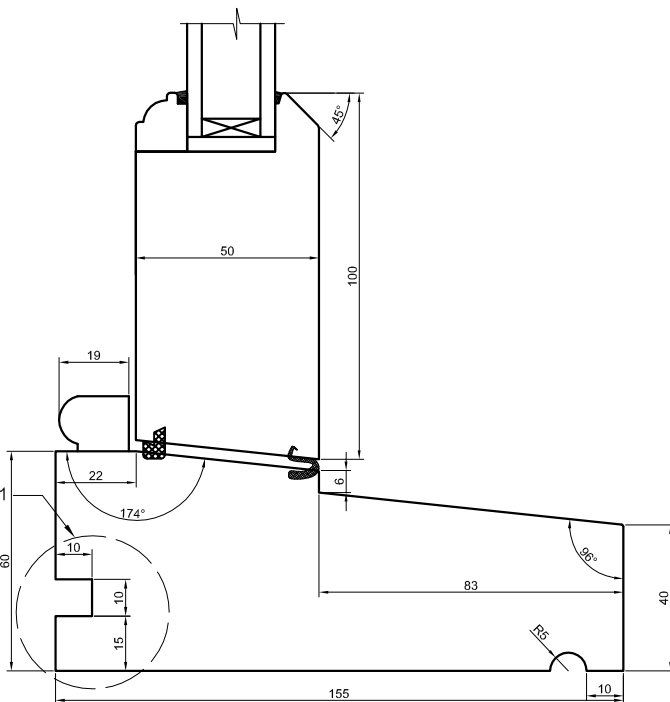
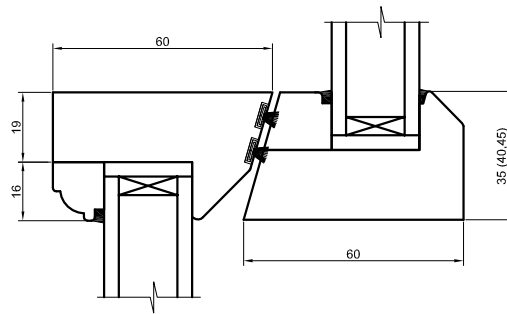
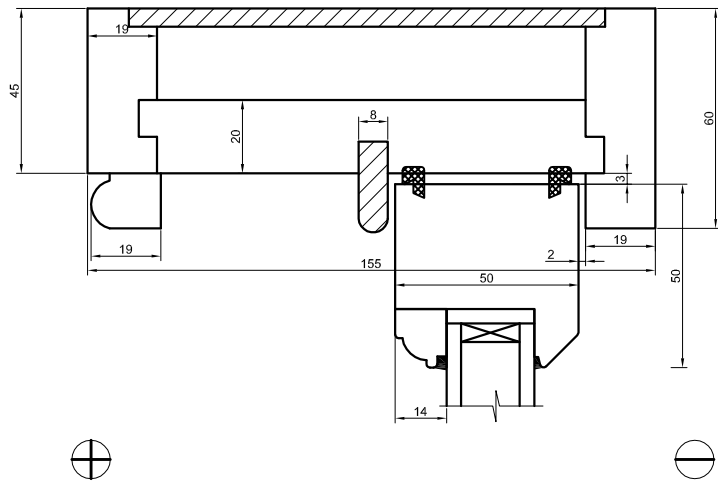

					Vertical section	
-					Sash Window	
					0	
					Spiral balance	
				2	2	

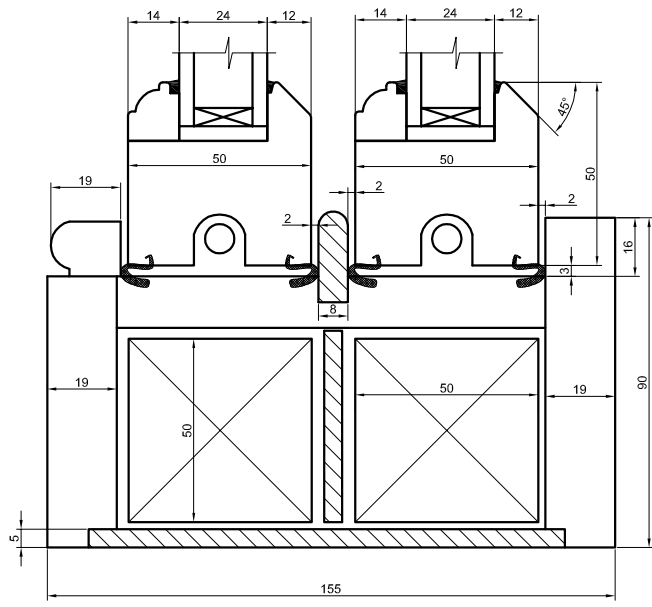
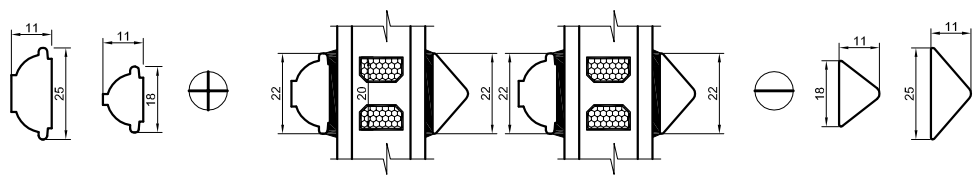
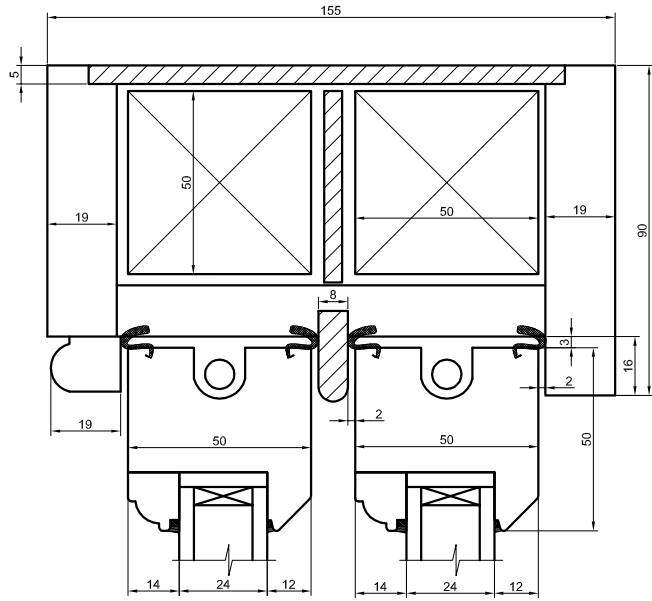

		Horizontal section		
-		Sash Window		
				0
		Cords & weights		
			1	2

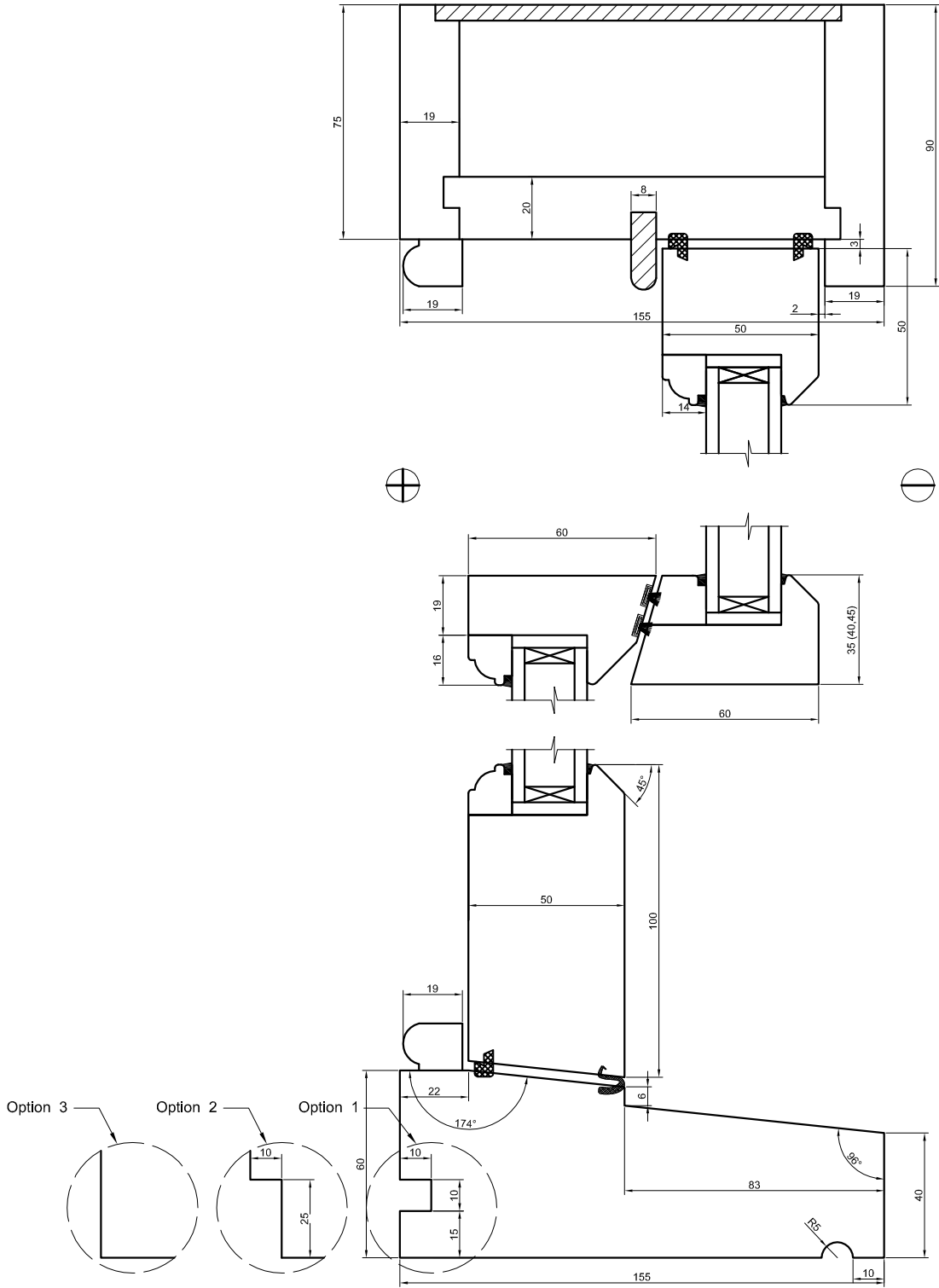

		Vertical section		
-		Sash Window		
				0
		Cords & weights		
			2	2

Test date: 2013-08-02

Description of test conditions:

Size of the sample, $H_T = 1,48$ m; $B_T = 1,23$ m; $H_0 = 0,75$ m; $B_0 = 1,08$ m.

Air temperature, 24,0 °C
Relative humidity of the air, 54 %
Atmospheric pressure, 99,98 kPa

Number of water spray nozzles 4 vnt.
Flow rate/ water spray nozzles 2 l/min.
Test method A

Test pressure **P1 1200 Pa** (3 class)

Test pressure **P2 600 Pa** (3 class)

Test pressure **P3 1800 Pa** (3 class)

Length of the members whose frontal deflection is to be measured **L = 980 mm**

Water watertightness detection results

Classification of watertightness

P, Pa	time, min.	S, NS
0	15	S
50	5	S
100	5	S
150	5	S
200	5	S
250	5	S
300	5	S
450	3 min.	NS
600		

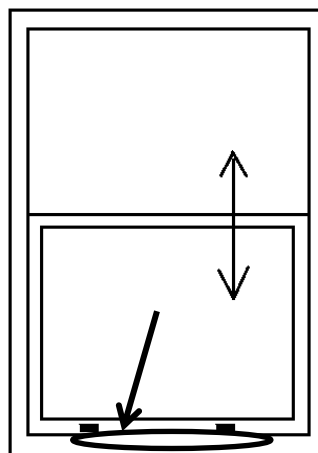

*Fig 2. Picture of window.
Arrows shows point of water penetration*

Note: Letter **S** mean water not penetration at this pressure. Letter **NS** means water penetration at this pressure.

Water penetrated at the positive test pressure **450 Pa** after 3 minutes. Watertightness class **7A** according to LST EN 12208:2002.

Evaluated in accordance with test results.

Validity – the named data and results refer exclusively to the tested and described specimens.
Notes on publication – no part of this document may be photocopied, reproduced or translated to another language without the prior written consent of the Science Laboratory of Building Thermal Physics.

The results of air permeability measurements:

Table 1. Air permeability at the normal conditions $t = 23\text{ }^{\circ}\text{C}$, $P_{atm} = 102,64\text{ kPa}$

P, Pa	V_{0t} , m^3/h	V_{0n} , m^3/h	V_{0vid} , m^3/h	V_A , $\text{m}^3/\text{h}\cdot\text{m}^2$	V_L , $\text{m}^3/\text{h}\cdot\text{m}$	The standard air permeability of all over the area V_A , $\text{m}^3/\text{h}\cdot\text{m}^2$				The standard air permeability to the length of opening joins V_L , $\text{m}^3/\text{h}\cdot\text{m}$			
						Class 1	Class 2	Class 3	Class 4	Class 1	Class 2	Class 3	Class 4
50	2,8	3,0	2,9	1,60	0,80	31,5	17,01	5,67	1,89	7,87	4,25	1,42	0,47
100	5,6	4,6	5,1	2,81	1,40	50	27	9	3	12,5	6,75	2,25	0,75
150	7,5	6,7	7,1	3,90	1,94	65,52	35,38	11,79	3,93	16,38	8,85	2,95	0,98
200	9,0	7,9	8,4	4,63	2,30		42,86	14,29	4,76		10,71	3,57	1,19
250	10,4	9,9	10,2	5,59	2,78		49,73	16,58	5,53		12,43	4,14	1,38
300	11,6	10,8	11,2	6,15	3,06		56,16	18,72	6,24		14,04	4,68	1,56
450	15,0	14,0	14,5	7,97	3,96			24,53	8,18			6,13	2,04
600	18,3	16,1	17,2	9,44	4,70			29,72	9,91			7,43	2,48

V_{0t} – air permeability at the positive test pressure;

V_{0n} – air permeability at the negative test pressure;

V_{0vid} – average of the two air permeability values;

V_A – air permeability to the overall area;

V_L – air permeability to the length of opening joins.

Air permeability dependence on an overall area and length of opening, graphic expression of the calculated air average values:

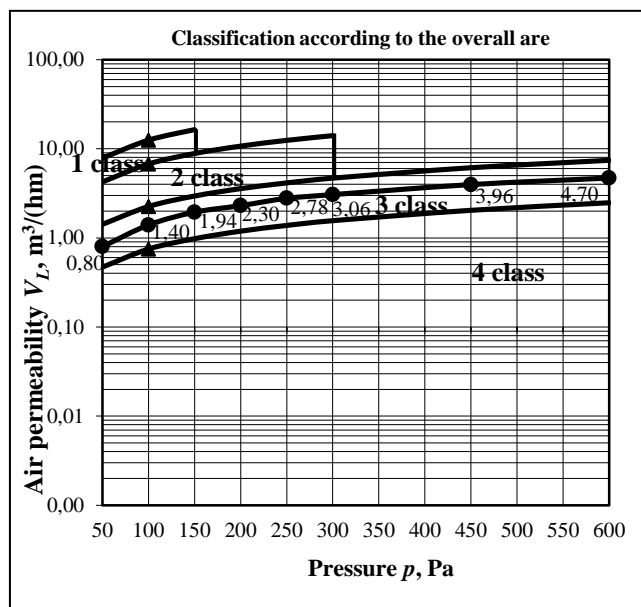
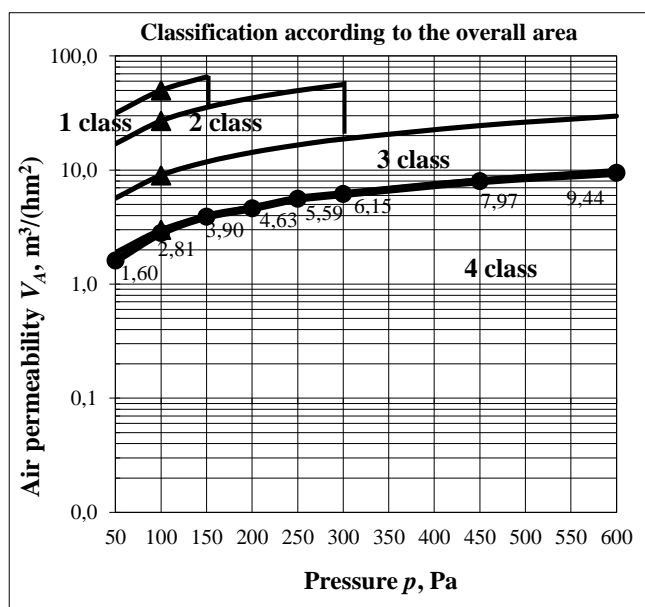

Validity – the named data and results refer exclusively to the tested and described specimens.

Notes on publication – no part of this document may be photocopied, reproduced or translated to another language without the prior written consent of the Science Laboratory of Building Thermal Physics.

The tested specimen, after comparison of V_A and V_L result values with the adequate values in table 2 and also in accordance with classification rules in LST EN 12207:2002, is classified to:

- the overall area – **3 class**;
- the length of opening joints – **3 class**;
- the final classification of the specimen – **3 class**.

Evaluated in accordance with test results.

Resistance to wind load results

1. Deflection test (test pressure P1):

Positive pressure (+P1)

$A = 1,0$ mm, $B = 1,8$ mm, $C = 0,9$ mm.

Frontal displacement $D_p = B = 1,8$ mm;

frontal deflection $F_p = B - [(A+C)/2] = 0,9$ mm;

relative frontal deflection $F_{rp} = F_p/L = 1/1153$

residual frontal displacement, when $P = 0$,

$D_p = 0,2$ mm;

Negative pressure (-P1)

$A = -0,6$ mm, $B = -1,6$ mm, $C = -0,8$ mm.

Frontal displacement $D_p = B = -1,6$ mm;

frontal deflection $F_p = B - [(A+C)/2] = -0,9$ mm;

relative frontal deflection $F_{rp} = F_p/L = -1/1089$,

residual frontal displacement, when $P = 0$ Pa,

$D_p = -0,2$ mm;

Resistance to wind load, frame deflection, class **C**

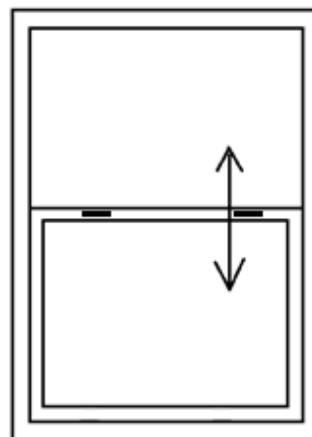

Fig 2. Picture of window.
Arrow show point of air permeability

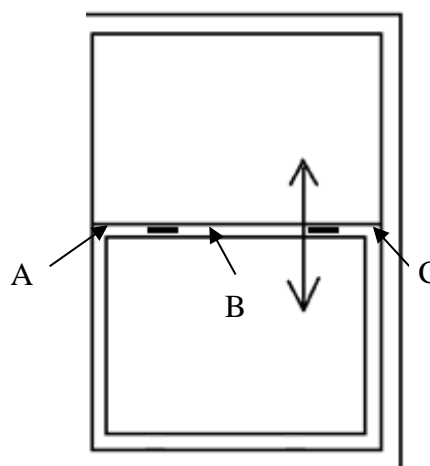

Fig. 3 Picture of window
A, B, C – deflection measuring points

2. Repeated pressure test (test pressure P2):

Note damage or functioning defects if any after the test: **No**

3. Test for air permeability in accordance with EN 1026:2004:

Air permeability did not exceed more 20% the air permeability of class (3) limits

4. Safety test (test pressure P3):

Note damage or functioning defects if any after the test: **No**

5. Tested specimen meets the resistance of wind loads **C3** class.

Evaluated in accordance with test results.

Validity – the named data and results refer exclusively to the tested and described specimens.
Notes on publication – no part of this document may be photocopied, reproduced or translated to another language without the prior written consent of the Science Laboratory of Building Thermal Physics.

The measurement of air permeability after cyclic loading according to LST EN 1026:2004 standard:

Size of the sample: $H_T = 1,48$ m, $B_T = 1,23$ m, $H_0 = 0,75$ m, $B_0 = 1,08$ m

Total area of the sample: $A = H_T \times B_T = 1,82$ m², opening joints length: $L = 2 H_0 + 2 B_0 = 3,66$ m

Table 2. Air permeability of the positive test pressure after cyclic loading to normal conditions $t = 24^{\circ}C$, $P_{atm} = 99,98$ kPa; V_L - air permeability to the length of opening joints, V_A - air permeability to the overall area

P, Pa	V_{0t} , m ³ /h	V_{0n} , m ³ /h	V_{0vid} , m ³ /h	V_A , m ³ /h·m ²	V_L , m ³ /h·m	The standard air permeability of all over the area V_A , m ³ /h·m ²				The standard air permeability to the length of opening joints V_L , m ³ /h·m			
						Class 1	Class 2	Class 3	Class 4	Class 1	Class 2	Class 3	Class 4
50	2,9	2,9	2,9	1,60	0,80	31,50	17,01	5,67	1,89	7,87	4,25	1,42	0,47
100	5,7	4,6	5,2	2,83	1,41	50,00	27,00	9,00	3,00	12,50	6,75	2,25	0,75
150	7,6	6,8	7,2	3,96	1,97	65,52	35,38	11,79	3,93	16,38	8,85	2,95	0,98
200	9,2	8,1	8,6	4,73	2,35		42,86	14,29	4,76		10,71	3,57	1,19
250	10,6	10,0	10,3	5,67	2,82		49,73	16,58	5,53		12,43	4,14	1,38
300	11,7	10,9	11,3	6,20	3,09		56,16	18,72	6,24		14,04	4,68	1,56
450	15,2	14,2	14,7	8,08	4,02			24,53	8,18			6,13	2,04
600	18,5	16,2	17,3	9,52	4,74			29,72	9,91			7,43	2,48

Air permeability values in the wind resistance of the load test recurring load pressure P2:

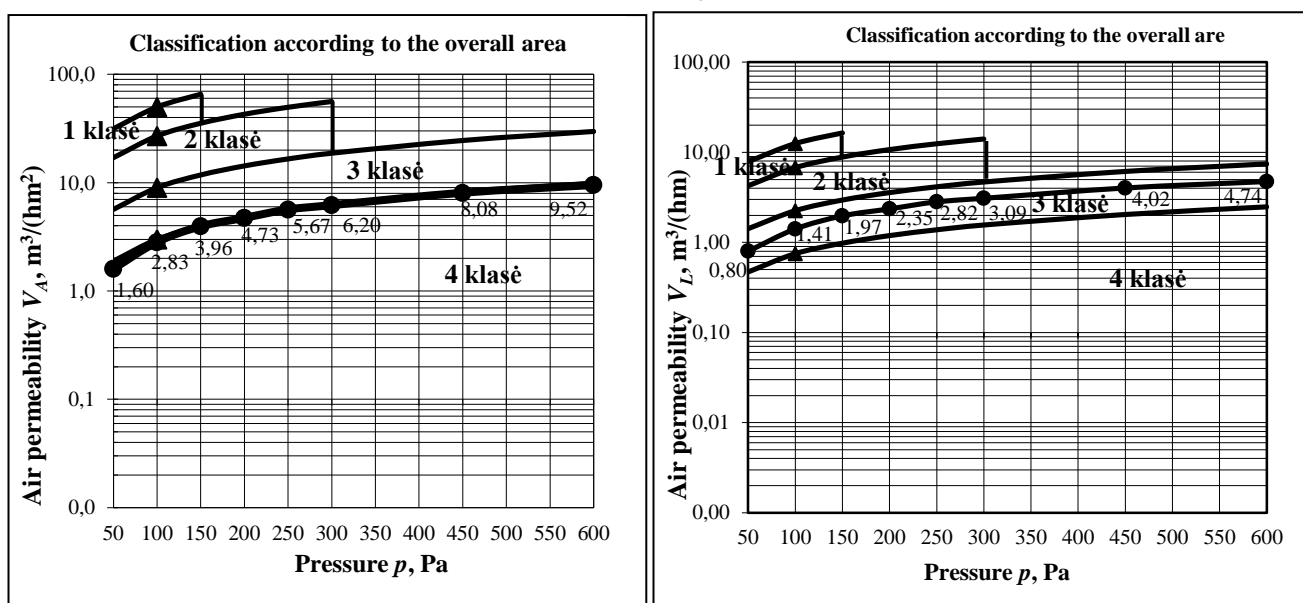

In table 2 the V_A and the V_L limit values, based on the formula $Q = Q_{100}(P/100)^{2/3}$ [2], defining the specific air permeability boundaries of class. Compared V_A , the V_L values, received during the test, to limit the estimated given to the air permeability class values, to determine the sample air permeable class. Air permeability did not exceed more 20% the air permeability of class (3) limits. Evaluated in accordance with test results.

Validity – the named data and results refer exclusively to the tested and described specimens.
Notes on publication – no part of this document may be photocopied, reproduced or translated to another language without the prior written consent of the Science Laboratory of Building Thermal Physics.

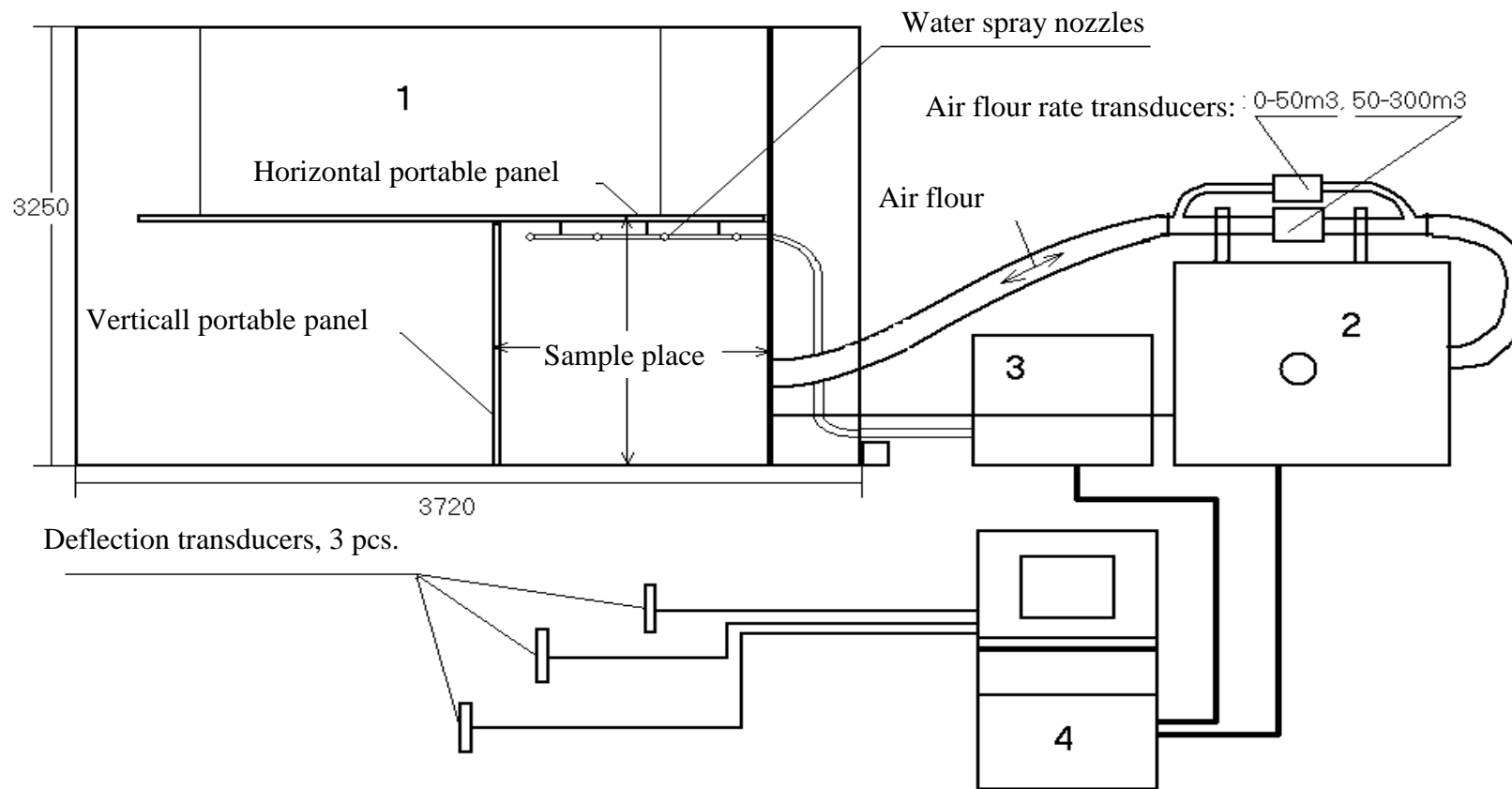

Fig 1. Equipment for window, door, roof window, industrial door and screen wall air permeability, rain water resistance and resistance to wind load measurements scheme: 1 – test measurement wall, 2 – air flow control and regulation block, 3 – water spray device, 4 – indicator and control equipment